

MODEL ROCKET NEWS

Try Sectional Construction!

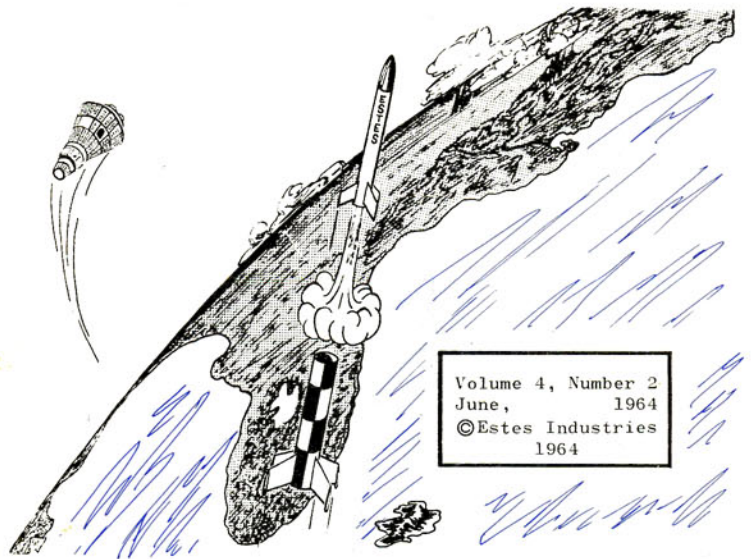

Volume 4, Number 2
June, 1964
©Estes Industries
1964

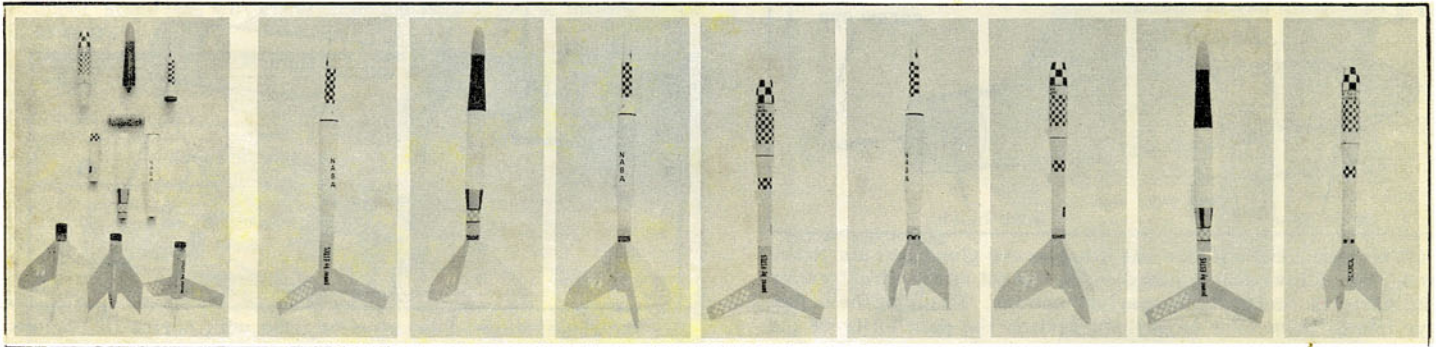

Model rocketeers are natural-born experimenters. The fantastic variety of models they produce is proof of their "no holds barred" approach to rocket building. The model-making technique known as "sectional construction" is a natural for the experimenter since it allows quick changes in a design to fit the need of the moment.

In sectional construction the rocket is divided into four parts: Engine-fin unit, 'chute unit, payload unit and nose cone. With just two different examples of each section it is possible to assemble 24 different rockets. Let's look at how this works for rockets based on BT-20.

The engine-fin unit is assembled from a 2-3/4" long BT-20J. The fins are glued to the rear and a JT-20C stage coupler is glued to the front--1/4" of it inside the body and 1/2" projecting forward outside the end of the body as in Fig. 1. The launching lug is glued to a fin 3/16" away from the body tube so a BT-50 size 'chute or payload unit may be mounted on the rocket if de-

sired. The engine is held in place in the unit by wrapping it with tape in the normal manner. The stage coupler acts as an engine block.

The 'chute section normally consists of a length of body tube with a shock cord attached to one end of the tube as in Fig. 2.

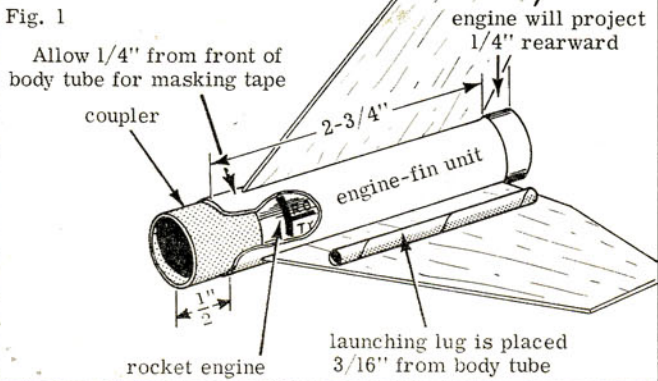
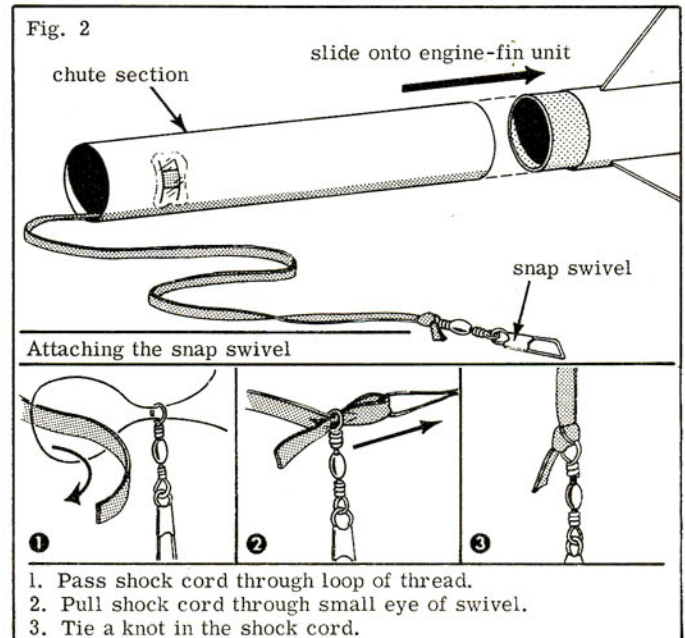

A snap swivel is attached to the free end of the shock cord to allow easy changes of nose cones or payload sections. More advanced 'chute sections may be made using other tube sizes as shown in Fig. 3.

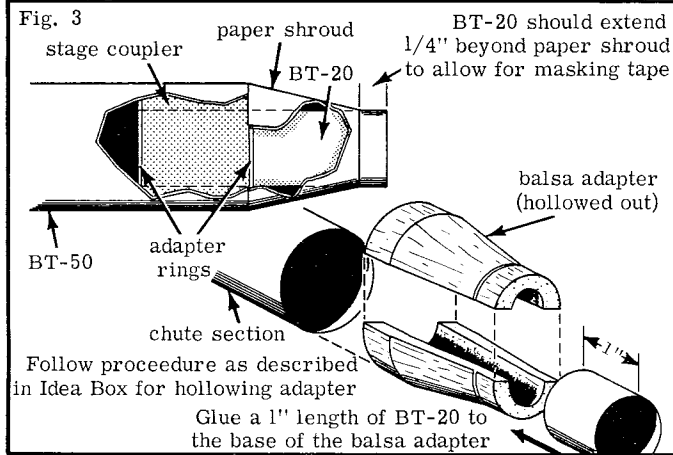

The payload unit consists of another length of body tube and a nose block or an adapter to fit the 'chute section. A screw eye is glued into the lower end of the nose block or adapter by inserting the eye, removing it, squirting glue into the hole and reinserting the screw eye. A typical payload section is shown in Fig. 4.

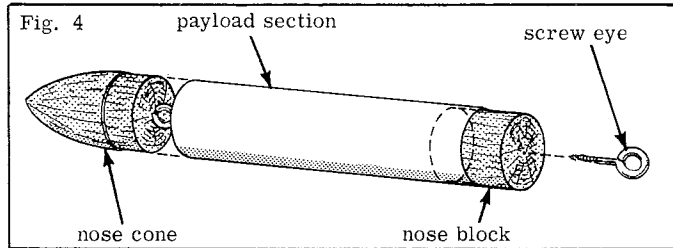

The nose cone unit also has a screw eye glued into its lower end. This allows it to be used on the rocket either directly over the 'chute section or with a payload section. By gluing the screw eye into the nose cone or payload section the possibility of the screw eye pulling out in flight is eliminated--once the glue has set the eye is firmly bonded to the fibers of the wood itself.

After the various units have been assembled, securely glued, etc., paint them well. Three or more coats of enamel paint or butyrate dope are necessary to hold up to the type of hard use you'll put these units through.

When the time comes to assemble a rocket and fly it, first slide a 'chute section onto an engine-fin unit. Hold the two pieces together securely by wrapping a single layer of 1/2" wide masking tape around the joint as shown in Fig. 5. Select a payload

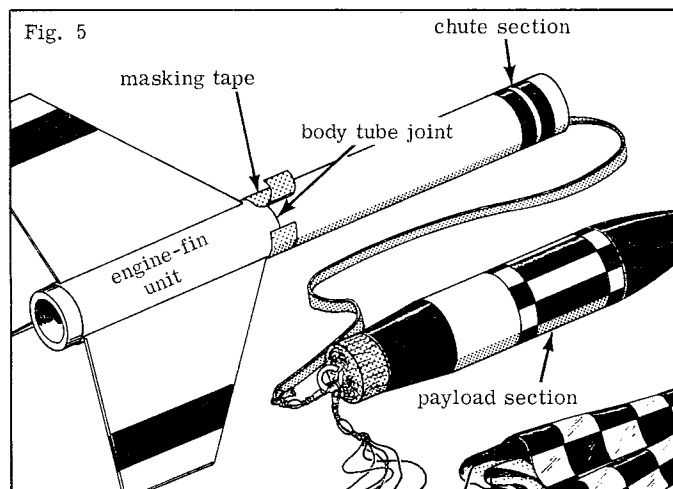

section and hook the snap swivel on the shock cord to the screw eye in the base of the payload section. Attach a parachute to the screw eye. Select a nose cone and place it in the forward end of the payload section.

Pack wadding into the 'chute section, fold the parachute and

pack it in. Wrap enough masking tape around an engine to make a tight friction fit in the tube and push it into place. Place an igniter in the engine, check the rocket for stability and you're ready to go.

Some of the applications you may find for sectional construction include testing different payload section designs, testing different nose cone designs, trying out various recovery systems and evaluating different fin designs. Other advantages available with this type of construction include the flying of special payloads without having to build complete special rockets, easy replacement of damaged portions of the rocket in case of accident and easy construction of really fantastic-appearing models.

To add to the usefulness of this system, an engine-fin unit can usually be converted to upper stage use by simply sliding an EB-20A engine block into the body to space the engine so it projects 1/2" rearward from the tube. The engine block fits tightly against the bottom of the stage coupler as in Fig. 6, but is not glued in place--it can be removed for single stage flying. It is especially important to check the stability of an upper stage concocted in this way since the engine weight is further rearward than in the unit as it was originally designed.

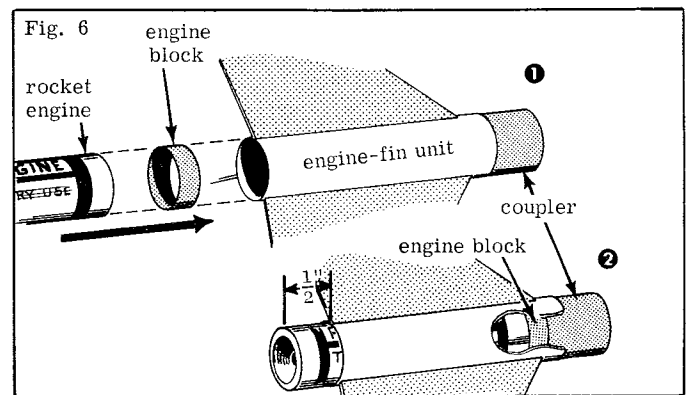

The engine-fin unit can also be used with Series III engines by cutting a JT-50C stage coupler lengthwise as in Fig. 7A and inserting it into the body by curling it together as in Fig. 7B. This spacer should rest against the JT-20C. The spacer can be easily removed to convert back to Series I and II engines.

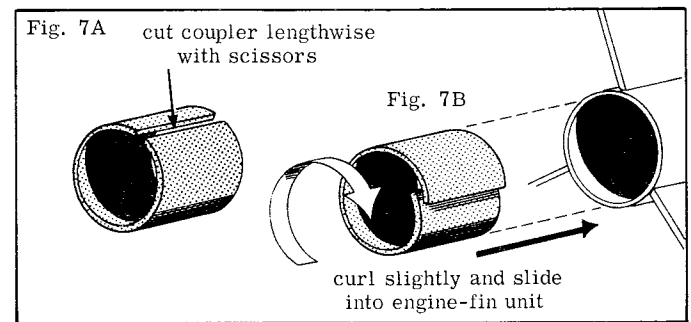

Another way to arrange launching lugs on rockets built for sectional use is to glue two lugs to the engine-fin unit--one beside the other along a fin as shown in Fig. 8. A short (1/4") piece of launching lug is then glued to the side of each large diameter payload or 'chute section to provide additional guidance.

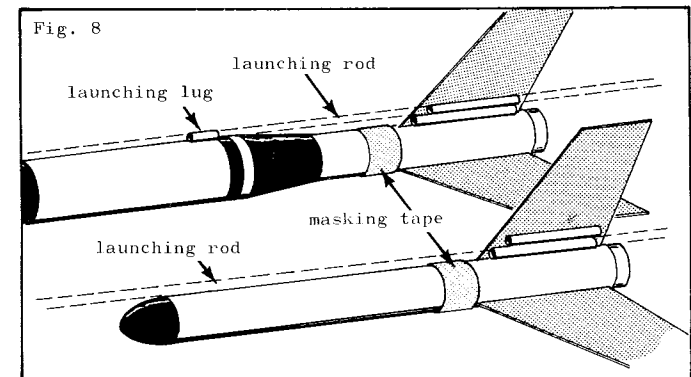

NEW PRODUCTS

Engine Holder

New flat spring steel design gives easy installation and low drag. Recommended especially for sport and demonstration models built from BT-20 and BT-30, the engine holder is 2.8" long, 0.1" wide and only 0.025" thick. Mount it on the model with glue and gauze as shown. Net weight 0.032 oz. each, shipping weight 1 oz.

Cat. No. 641-EH-2 \$.15 each, 3 for \$.30

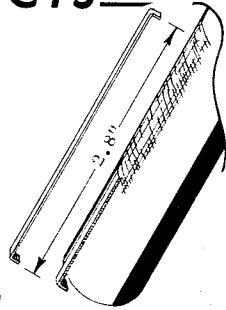

Short Engine Holder

Specially designed for use with Series III engines and BT-20 and BT-30 body tubes, this holder is 1.8" long and 0.1" wide for the same easy installation and low drag as the standard model. Net weight 0.022 oz. each, shipping weight 1 oz.

Cat. No. 641-EH-3 \$.15 each, 3 for \$.30

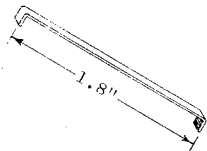

Astron Sprite

A perfect model for small fields and sport or demonstration flying. The new Astron Sprite is easy to build, with tumble recovery to teach principles of rocket balance and bring the model back safely--close to the launcher. Uses lightweight Series III engines only, gives top performance for its size. Completed model is 5.3 inches long, weighs 0.3 ounce. Complete kit, less engines, only \$.75.

Cat. No. 641-K-15 \$.75 each

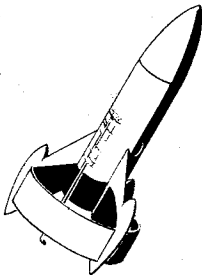

The Best From Volumes 1 and 2

Sixteen pages packed with articles readers have chosen as best from volumes 1 and 2 of the MRN. Includes plans, Idea Boxes, Technical Report TR-3, stories on crickonaut and guppy launchings, and much more. Shipping weight 3 oz.

Cat. No. 641-MRN-1 \$.50 each



MODEL ROCKET NEWS

The Model Rocket News is published four times annually by Estes Industries, Inc., Penrose, Colorado. It is distributed free of charge to all the company's mail order customers from whom a substantial order has been received within a period of one year. The Model Rocket News is distributed for the purpose of advertising and promoting a safe form of youth rocketry and for informing customers of new products and services available from Estes Industries. Rocketeers can contribute in several ways towards the publication of the Model Rocket News:

- (1) Write to Estes Industries concerning things you and your club are doing in this field which might be of interest to others.
- (2) Continue to support the company's development program by purchasing rocket supplies from Estes Industries, as it is only through this support that free services such as the Model Rocket News, rocket plans, etc., can be made available. This support also enables the company to develop new rocket kits, engines, etc.
- (3) Write to the company about their products and tell what you like, what you don't like, new ideas, suggestions, etc. Every letter will be read carefully, and every effort will be made to give a prompt, personal reply.
- (4) Participate in the Writer's Program (described on page 7). Not every article submitted will be accepted, but through trying skill is gained and those which are accepted contribute greatly to other persons' enjoyment of model rocketry.

Vernon Estes
Publisher

William Simon
Editor

Rocket Math

Model rocketeers' tools normally include knives, sandpaper, paint brushes, etc. Simple math, too, can be a valuable tool for the serious modeler. With a few basic formulas the rocketeer can quickly find G forces, rocket speeds, theoretical altitudes and actual altitudes. Technical Report TR-3 covers tracking models and computing actual altitudes in considerable detail--this article is a quick survey of some other things a rocketeer can calculate to help him build better models.

Because model rockets fly in the atmosphere aerodynamic drag is important in determining how high a rocket will go. Unfortunately, the rocketeer rarely has access to a wind tunnel capable of measuring the drag on his models. Typically, drag will reduce the peak altitude of a shortened Astron Streak with a 1/2A.8-4S engine aboard from a theoretical, drag-free 1935 feet to an actual 710'. It has been found that an average model built from BT-10, 20 or 30 will have a drag force in ounces of approximately $D = 0.000045V^2$ exerted on it in flight. (The symbol V^2 represents the speed of the rocket multiplied times itself: At a speed of 10 feet per second V^2 equals 10×10 or 100, and drag on the rocket is approximately 0.0045 oz.) When the speed is doubled, the drag becomes four times as great. We'll look at drag some more later on in this article.

How Much Will it Accelerate ?

1. How do we calculate the rocket's potential performance? G forces on a rocket in space are found with the formula $G = \frac{F}{W}$. F represents the thrust of the engine and W the weight of the rocket (including engine, payload, etc.). A 1 oz. rocket being pushed by 18 oz. of thrust is subjected to a G force of 18. A 1/2 oz. rocket with the same thrust undergoes 36 G's, while a 2 oz. rocket with 18 oz. of thrust only gets 9 G's. Since one G is equal to the force of earth's gravity, a 1/4 oz. payload in a rocket accelerating at 10 G's is subjected to a force ten times its weight or 2.5 ounces.

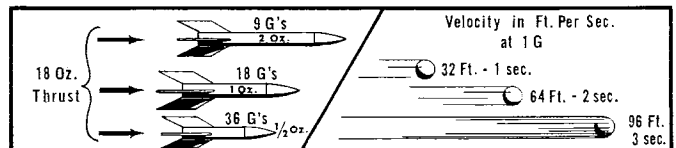

2. If we know how many G forces the rocket is undergoing we can determine how much speed it will gain in a given length of time. Sir Isaac Newton discovered that an object being pulled down through space at 1 G (the force of earth's gravity) gains 32 feet per second speed for each second it falls. If, for example, we drop a cannon ball from a cliff it will be traveling 32 feet per second at the end of 1 second, 64 ft./sec. at the end of two, 96 ft./sec. at the end of three, etc.

3. In a rocket traveling up vertically we have this same force of gravity working to pull the rocket back. One G of the rocket's acceleration is spent simply to counteract the force of gravity. Expressing this mathematically the actual upward acceleration of a rocket in G's is equal to the thrust divided by the weight minus one $G = (\frac{F}{W} - 1)$.

4. When the rocket's upward acceleration in G's is multiplied by 32 (called "the gravitational constant") we find the rocket's "instantaneous acceleration." The formula for finding this is $A_0 = (\frac{F}{W} - 1) 32$. By multiplying the instantaneous acceleration by the duration of acceleration we find the velocity at the end of the time.

For Example ...

5. Joining all this together, let's see how it works out in practice. John Doe has a featherweight rocket that weighs 0.535 oz. at takeoff with a 1/2A.8-4S engine aboard. The propellant in the engine weighs 0.07 oz. The first step is to find the average weight of the rocket during its flight. If it weighs 0.535 oz. at

NOTES FROM THE BOSS

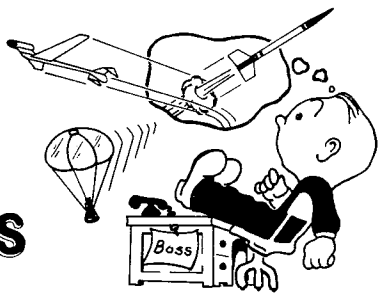

A couple of years back Capt. Dave Barr of the Air Force Academy surveyed the field of model rocketry and decided a lot of modelers were torturing mice unnecessarily. It seems the rage then was to shove a mouse into the payload section of just about any rocket, put a big engine under him, shoot him up and see if he'd survive. This, of course, was neither scientific nor humanitarian. Capt. Barr suggested that rocketeers should prove their skill using eggs before trying to launch mice. Egg flying has since become a quite popular sport.

The rocketeer can often learn more about the effects of acceleration, shock, etc. on organic objects from an egg than from mice--once the egg is damaged, it's easy to see, while internal injuries to a mouse may not be evident--especially if the mouse is mishandled afterwards. It's also possible the mouse may have been injured before the flight, and his previous injuries can combine with the effects of the flight to kill him.

Flying an egg isn't necessarily easy. We've seen a rocketeer who's been with the hobby since 1957 scramble his because of inadequate rocket design. On the other hand, a wide variety of rocket types can be used for successful flights. Best results come with cluster type single stage models and non-cluster multi-stage models. Farsides and Rangers can be used with small eggs, but a special payload section is necessary for larger eggs. Lots of padding and a plastic bag around the egg itself will help.

After the flight, if the shell is still uncracked, carefully open the egg and see if the yolk is intact. Or, if you can get hold of some fertile eggs from a poultry supply outlet, stick the egg in an incubator and see if it hatches in the normal time. Better still, take a couple of dozen eggs, fly half and use the others as a control group. Incubate both batches under exactly identical conditions and you've got a science fair project.

While egg flying started with model rocketeers, professional scientists have seen its values also. One current proposal is for a satellite which would carry several eggs in an incubator. Biosensors in the eggs would monitor the development of the embryo chicks to give our scientists valuable information on the effects of space travel conditions on the basic processes of life.

Have Brochures... Will Send!

Now available through Estes Industries' free plan service are two brochures designed to help modelers tell the story of model rocketry to their friends, teachers, etc. These brochures are "Introducing the New Horizons of Model Rocketry," a brief explanation of the nature of model rocketry and some of its values and "Teaching for Tomorrow," an introduction to the educational values and uses of model rocketry.

The "Introducing" brochure is especially valuable to modelers looking for new members for clubs and in explaining model rocketry to other prospective hobbyists. The "Teaching for Tomorrow" brochure is quite useful in explaining model rocketry to science teachers and educators as well as other education-minded persons.

Sample copies of these brochures are available on the same basis as plans and other materials on the Customer Service section of the Clip 'N' Mail Page (see the inside of this issue's wrapper). The brochures will be sent free of charge to all who mail in the coupon with the appropriate squares checked and enclose a stamped, self-addressed envelope with their request.

BOOST GLIDER DESIGN COMPETITION

Take a good look at the list of prizes that go to the winners of this contest. Then sit down and design and build the perfect boost-glider. When you're through testing the rocket, send the plans, parts list and instructions to: Boost-Glide Contest, Box 227, Penrose, Colorado, 81240.

- 1st Prize--\$50 in merchandise credit.
- 2nd Prize--\$25 in merchandise credit.
- 3rd Prize--\$10 in merchandise credit.
- 4th Prize--\$5 in merchandise credit.

5th through 10th Prizes--Astron Farside Kits.

CONTEST RULES

- 1) All plans must be drawn to scale. Pencil or ink drawings are acceptable.
- 2) A parts list must accompany each entry.
- 3) Each entry must be flight tested to assure that it has suitable flying characteristics.
- 4) Only boost-glider designs will be qualified.
- 5) The center of gravity for the complete rocket and each individual stage must be marked on the plan.
- 6) Sufficient information must accompany the entry to allow judges to build an exact duplicate of the original model.
- 7) Employees of Estes Industries and members of their immediate families are not eligible to enter this contest.
- 8) The decision of the judges is final.
- 9) Entries must be postmarked no later than August 31, 1964.
- 10) All designs submitted become the property of Estes Industries, Inc. No plans or designs will be returned.

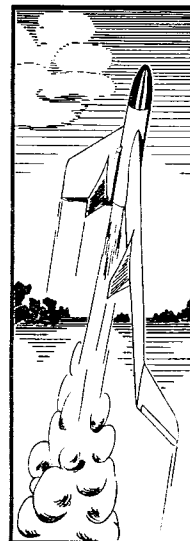

Enter Now! ESTES SCIENCE FAIR!

Did you use model rocketry in a science fair project this year? If so, we've got a special contest for you. To enter, just send photos of your exhibit, a general description of the project and a copy of your report to: Science Fair Contest, Box 227, Penrose, Colorado, 81240. If your project is picked as one of the best by the judges, you can win one of these great prizes.

- 1st Prize--\$50 in merchandise credit.
- 2nd Prize--\$25 in merchandise credit.
- 3rd Prize--\$10 in merchandise credit.
- 4th Prize--\$5 in merchandise credit.

CONTEST RULES

- 1) Each entry must include a photo of the exhibit as used in the actual science fair, a general description of the nature and extent of the project, a copy of the report used in the project and a statement signed by your teacher or parent certifying that the entry depicts the project as it actually was entered in the fair.
- 2) Entries must be postmarked no later than July 31, 1964.
- 3) Employees of Estes Industries and members of their immediate families are not eligible to enter this contest.
- 4) The decision of the judges is final.
- 5) All entries become the property of Estes Industries, Inc. No material will be returned.

NOTE: Prizes previously won by the project will not be considered in judging entries. However, the Editor would appreciate it if you would include such information.

ROCKET MATH Continued from page 3...

takeoff and burns 0.07 oz. of fuel, at burnout it will weigh 0.465 oz. The average weight is $\frac{.535 + .465}{2} = .50$ oz. The engine's average thrust is 14 oz. (found by dividing the total impulse by the duration as listed in the engine selection chart in the catalog. Multiply pounds by 16 to find the number of ounces.) The time (duration of thrust) is 0.4 second. The formula for velocity is $V = (\frac{F}{W} - 1) 32t$, so we enter the values for thrust, weight, etc. in their proper places to get a formula that reads $V = (\frac{14}{.5} - 1) 32 \times .4$.

- Step 1. Divide 14 by .5 ($\frac{14}{.5} = 28$).
- Step 2. Subtract 1 ($28 - 1 = 27$).
- Step 3. Multiply 27 by 32 ($27 \times 32 = 864$).
- Step 4. Multiply 864 by .4 ($864 \times .4 = 345.6$ ft./sec.).

Compare these steps with the formula for velocity to see how it is used in actual computations.

6. John has a heavier rocket that weighs 1.605 oz. with a B.8-6 engine aboard. The propellant in the engine weighs 0.21 oz. The engine delivers an average thrust of 13.14 oz. for 1.4 seconds. Using the formula $V = (\frac{F}{W} - 1) 32t$, what will the rocket's theoretical velocity be at burnout?

- Step 1. Find the average weight of the rocket.
- Step 2. Divide average thrust by average weight.
- Step 3. Subtract 1.
- Step 4. Multiply by 32.
- Step 5. Multiply by time (duration of thrust).

7. The distance an object travels is equal to its average velocity multiplied by the length of time. A car averaging 60 miles an hour for 2 hours covers 120 miles. A rocket traveling 200 feet per second for 3 seconds goes 600 feet. Since the speed of a model rocket changes constantly during its flight, we need some way of finding a fairly accurate average speed. To do this we break the rocket's flight into several parts called "intervals."

8. If we select the time from takeoff to burnout as an interval on John's featherweight rocket (see paragraph 5) we find that the rocket's velocity at the beginning of the interval is zero feet per second and 345.6 feet per second at the end of the interval. Assuming that the rocket accelerated at a constant rate during this time we can add the initial speed and the final speed and divide by 2 to find the average speed. In this case 0 plus 345.6 equals 345.6, and 345.6 divided by 2 equals 172.8 feet per second average speed. Since the distance traveled is equal to the average speed multiplied by the time, $172.8 \times .4 = 69.12$ feet at burnout. The formula then is $H = \frac{V'' + V}{2} t$ where:

- V'' = Velocity at the beginning of the interval.
- V = Velocity at the end of the interval.
- t = Duration (time) of the interval.
- H = Distance traveled during the interval.

9. John's second rocket (see paragraph 6) reached a maximum velocity of 347.6 feet per second at burnout. The time from takeoff to burnout was 1.4 seconds. How high was the rocket at burnout?

- Step 1. Add initial velocity and final velocity (0 + 347.6).
- Step 2. Divide the sum of initial and final velocities by 2 to find the average velocity.
- Step 3. Multiply the average velocity by the time.

How High Will it Coast ?

10. If a falling object gains 32 feet per second velocity each second it falls, the same force of gravity will act on a rocket coasting upward and take away 32 feet per second of its velocity each second it coasts upward. By dividing the rocket's burnout velocity by 32 we can find the number of seconds the rocket would continue coasting upward under drag-free conditions.

11. A rocket with a burnout velocity of 160 feet per sec. would continue to coast upward for 5 seconds--until it lost all its upward velocity. To find the average velocity we add 160 and 0, then divide by 2, which gives us 80 feet per second. Multiplying average velocity by time we find that the rocket climbed 400 feet after burnout.

12. What would happen if a recovery system stopped the rocket's upward flight before gravity had taken away all the rocket's velocity? If the rocket in the last example is stopped after only four seconds we can still find the average velocity and the distance traveled. Since the rocket loses 32 feet per second each second, at the end of four seconds it will have lost 128 feet per second and will have a speed of 32 feet per second. Adding the initial and final velocities and dividing by 2, we find $\frac{160 + 32}{2} = 96$ feet per second average speed. Multiplying the average speed by the time (4 seconds) we find the rocket traveled 384 feet.

13. We can also determine how far the rocket traveled in the first second after burnout. Since the rocket was traveling 160 feet per second at burnout we just subtract 32 from 160 (V'') to find the velocity at the end of the first second (V = 128 feet per second). Adding V'' and V and dividing by 2 gives us an average speed of 144 feet per second. Multiplying by the time (1 second) we find that the rocket traveled 144 feet in the first second after burnout. The same principle can be used to find the distance traveled in any other part of the rocket's flight.

Total Theoretical Height

14. John's first rocket (see paragraphs 5 and 8) was traveling 345.6 feet per second at burnout. To find the distance it would travel after burnout we divide 345.6 by 32 to find out how many seconds it would continue upward. Our answer is 10.8 seconds.

Next we find the average velocity ($\frac{345.6 + 0}{2} = 172.8$) and multiply it by the time to find the distance ($172.8 \times 10.8 = 1866.24$ feet). Since we have already found that the rocket traveled 69.12 feet before burnout, we add the two distances (1866.24 and 69.12) to find the total distance traveled by the rocket. The sum of the two distances is 1935.36 feet, which is the theoretical, drag-free altitude reached by the rocket. Since the rocket was tracked optically to an actual altitude of 710 feet, it's easy to see how important drag is in the performance of a rocket.

15. John's second rocket (see paragraphs 6 and 9) reached an altitude of 243.32 feet at burnout and a velocity of 347.6 feet per second. How far did it travel after burnout? What was the rocket's total altitude?

DRAG

16. We mentioned before that drag on an average rocket made from BT-10, 20 or 30 is approximately $D = 0.000045V^2$. To calculate drag on a model at a certain speed we multiply the speed times itself times 0.000045. At 100 feet per second this would be $100 \times 100 \times 0.000045$ or 0.45 oz. This figure for drag was obtained by attaching models to a very sensitive scale in a wind tunnel. Readings from the wind tunnel were checked by computing altitudes and comparing the results with actual tracked altitudes achieved by various rockets. Calculated altitudes and actual altitudes usually compared within 10% for typical models.

17. During the powered phase of a rocket's flight drag will act against thrust to reduce the acceleration of the rocket, the distance it will travel and its velocity at burnout. After burnout drag combines with gravity to slow down the rocket and further reduce the distance it will travel.

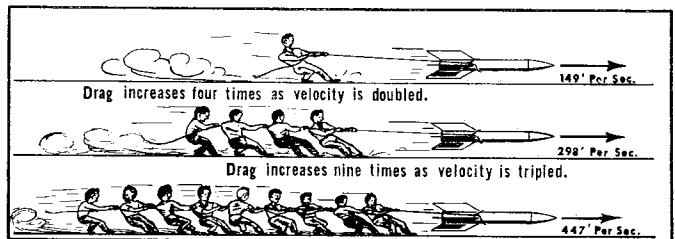

18. When drag is included in our calculations the formula for upward acceleration in G's becomes $G = (\frac{F-D}{W} - 1)$. Since speed is constantly changing and drag changing even more, especially in the latter parts of powered flight, we must allow for these

Rocketry on Your Own

— or —

How to Goof and Like It!

by Bob Welch

(Any resemblance to certain model rocketeers may not necessarily be coincidental.)

The fine art of model rocketry requires special techniques from start to finish. Here are some time-honored methods guaranteed to get results--

The first thing to do when the order comes in the mail is to tear the package open and dump all the contents out onto a convenient table, bed or floor. After searching the packing material for the bigger items, throw the remaining papers away--there are never any small parts in them like the directions say. Those little slips with an operator's number and the statement "Please save this slip for any further correspondence" are only in there to make it look professional and impressive, so they can go too. As for the order blank and other papers returned with your order, do what you want with them. You sent the order, you ought to know what's in there and what isn't.

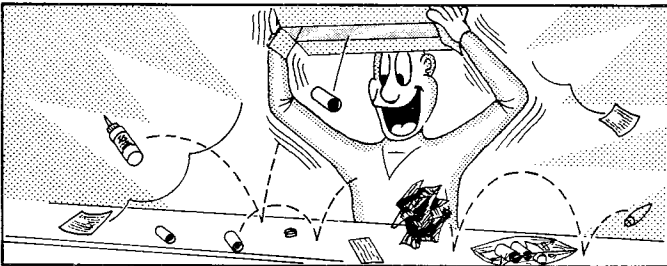

Now for the first package. Don't worry about tearing the papers inside the plastic sack; the only thing they're good for is directions. Any nut can put a rocket together, so hurry up and get the thing opened. Pour the contents of this package out just like the big carton. Throw that little "Correspondence" slip away. There'll never be any reason to write about the kit. Take a quick glance through a page or two of the directions--sometimes they've got interesting pictures.

Okay, ready to get at it now. Use the glue freely. Any glue that drips or runs won't hurt anything. If some lands on the carpet, ignore it. Contrary to what the directions say, the rocket will be easier to paint if the fin grain runs the long way on the model. It's much more streamlined than running the grain along the leading edge. They only say to line it up with the leading edge so they can sell more balsa.

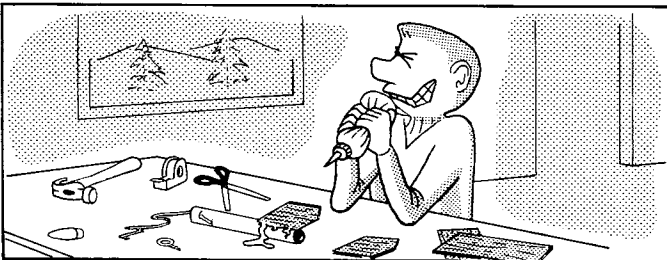

Use a dull knife to eliminate the chance of getting cut with it. If you're in a hurry you can save a lot of time on the fins. I cut mine with scissors. It's real fast and leaves a sort of splintery edge that's real good for gluing. If the directions say to use a ruler, approximate; there's no sense wasting time hunting for one, and a few fractions of an inch can't hurt. Skip that part about glue fillets. Any good glue only needs one application. It's just another trick to sell more glue.

Fit the nose cone real tight--the ejection charge is plenty powerful and the chance of the nose cone falling off in flight is eliminated. The parachute is a small matter. The only thing wrong with getting one string longer than the rest is that another

one will be a little shorter than the others. Screw the screw eye in so it doesn't fall out: Gluing is a waste of time.

Before painting sand the balsa a little so the leading edges of the fins aren't completely square. One coat of sanding sealer is plenty. The only reason they specify two or even three coats is to get rocketeers to run out sooner and have to buy more. Sanding after applying the sealer is optional. Might as well not waste time with it, since there won't be much difference when the paint is on. One coat of paint is enough. Too much will make the model heavy--just pick up the bottle to feel how much weight it adds. If you want to get fancy about it, put on some wax after the paint has dried. There's no difference between a rocket and a pair of shoes, so use lots and make sure the whole thing is covered.

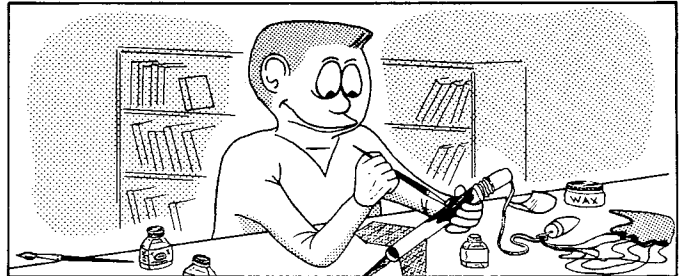

That was easy enough, and now it's ready for launch. Take the launch pad outside and put it any place handy. Those trees are downwind, so they won't bother anything. If the clips aren't too clean, brush them off on a fingernail. Pick any size engine. Only beginners need to use small engines for the first flights. No need to check for stability either. After a couple of models building stable ones just comes naturally. Put it on the rod and attach the clips at the ends of the igniter. This is important because it cuts down on wear on the clips and reduces time spent cleaning them. With the clips attached, back off a few steps and push the button. Mutter a few unkind words about the lousy nichrome when the engine fails to ignite and try cleaning the clips properly and attaching them a little farther up into the nozzle. Back off and push the button again.

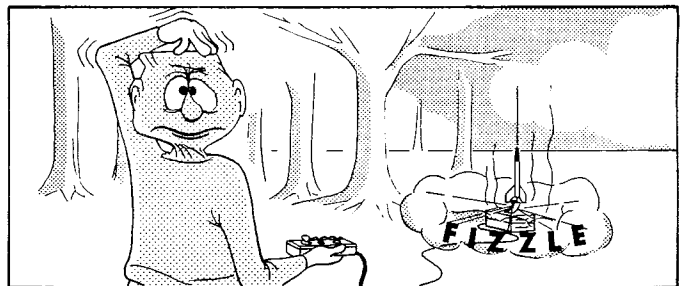

Now locate all the pieces and glue them back together. There are a million and one things to blame for tearing up that rocket--take your pick. With all the experience that went into its construction, though, it must have been the fault of the materials. It couldn't have been the construction. Maybe the next one will work better.

What Is the Writer's Program?

It's simply our way of encouraging you to contribute stories, technical reports, etc. to the MRN. We pay for the material we use by sending you merchandise certificates--2¢ of credit for each word in the article as published. Rocketeers are urged to submit any article which may be of general interest to other modelers.

Manuscripts should be typed double spaced on 8-1/2" x 11" paper. All articles must be accompanied by a statement signed by the contributor, and if he is a minor, by his parent or guardian, certifying that the article is his own original work. Articles published become the property of the Model Rocket News. This publication reserves the right to edit or alter any articles used, and will not be responsible for lost manuscripts and photos. Manuscripts can be returned only if accompanied by a self-addressed envelope and sufficient postage.

changes in making our calculations. By using smaller intervals than the full time to burnout and the full time after burnout we can achieve fairly accurate results. When we use the full formula $v = (\frac{F-D}{W} - 1) 32t$, intervals of 0.1 second up to burnout and for the first 1/2 second after burnout and 0.5 second intervals from there to peak altitude give good results. Answers from each interval are used in the next to determine drag and distance.

19. The flight history of a rocket is computed by the following steps:

1) Velocity added during the interval is computed:

$$V' = (\frac{F-D}{W} - 1) 32t'$$

F = Thrust.

D = Drag at the end of the previous interval (computed from the speed at the end of the previous interval).

W = Rocket weight.

t' = Length of the interval (time).

V' = Velocity added during the interval.

2) Total velocity in feet per second at the end of the interval is computed: $V = V'' + V'$ Where:

V'' = Velocity at the beginning of the interval.

V' = Velocity added during the interval.

V = Velocity at the end of the interval.

3) The distance traveled during the interval is computed:

$$H' = (\frac{V'' + V}{2}) t'$$

V'' = Velocity at the beginning of the interval.

V = Velocity at the end of the interval.

t' = Length of the interval (time).

H' = Distance traveled during the interval.

4) Total altitude at the end of the interval is computed:

$$H = H'' + H'$$

H = Total altitude in feet at the end of the interval.

H'' = Altitude in feet at the beginning of the interval.

H' = Distance traveled during the interval.

5) Drag in ounces at the end of the interval is computed:

$$D = 0.000045V^2 \text{ (or } D = 0.000045 \times V \times V)$$

V = Velocity at the end of the interval.

D = Drag at the end of the interval.

20. After burnout all these formulas are still used, but with one change--thrust (F) disappears. As a result, the formula for velocity becomes a formula for velocity lost: $v' = (\frac{-D}{W} - 1) 32t'$

where V' represents velocity lost during the interval. A minus number (-D) divided by a positive number (W) gives another minus number. When two minus numbers are added, the sum is another minus number. When a minus number is multiplied by a positive number the answer is a minus number. Thus if there were 1 oz. of drag on a 1 oz. rocket our formula would read $v' = (\frac{-1}{W} - 1) 32t'$. If the interval was 0.1 second, V' would be -6.4 feet per second.

21. What we are actually doing after burnout is calculating the number of G's deceleration $(\frac{-D}{W} - 1)$ and multiplying by the gravitational constant and the time. Drag is highest during the first few fractions of a second after burnout so the rocket decelerates most rapidly at this time. The charts below show lines for velocity, altitude, etc. for a 1 oz. rocket propelled by an A. 8-4.

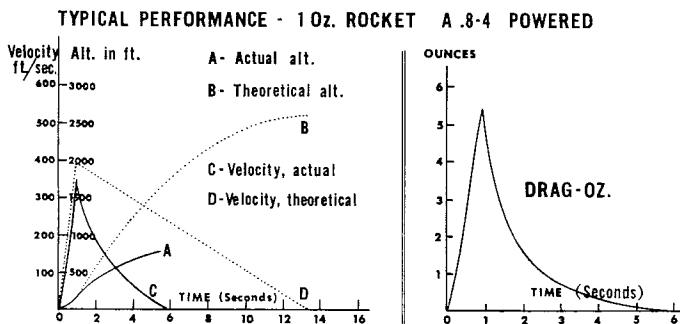

22. The charts show how important drag is in the performance of a model rocket. On this model drag reduced the peak altitude to 1/3 the theoretical, drag-free altitude. We find that drag is

Interval (time from takeoff in seconds)	Velocity at end of interval	Velocity change in interval	Altitude added in interval	Altitude at end of interval	Drag at end of interval	Theoretical velocity (no drag)	Theoretical altitude (no drag)
0.0 to 0.1	43.74	43.74	2.19	2.19	0.09	43.74	2.19
0.1 to 0.2	87.20	43.56	6.55	8.74	0.34	87.49	8.75
0.2 to 0.3	129.85	42.65	10.85	19.59	0.76	131.23	19.69
0.3 to 0.4	171.16	41.31	15.05	34.64	1.32	174.98	35.00
0.4 to 0.5	210.68	39.52	19.09	53.73	2.00	218.72	54.68
0.5 to 0.6	248.02	37.34	22.94	76.67	2.77	262.47	78.74
0.6 to 0.7	282.90	34.88	26.55	103.22	3.60	306.21	107.17
0.7 to 0.8	315.12	32.22	29.90	133.12	4.46	349.96	139.98
0.8 to 0.9	344.59	29.47	32.98	166.10	5.35	393.70	177.16
0.9 to 1.0	324.27	-20.32	33.44	199.54	4.74	390.50	216.37
1.0 to 1.1	305.90	-18.37	31.51	231.05	4.21	387.30	255.26
1.1 to 1.2	289.23	-16.67	29.76	260.81	3.77	384.10	293.26
1.2 to 1.3	273.97	-15.26	28.16	288.97	3.38	380.90	332.08
1.3 to 1.4	259.95	-14.02	26.70	315.67	3.04	377.70	370.01
1.4 to 1.5	247.02	-12.93	25.35	341.02	2.75	374.50	407.62
1.5 to 2.0	187.02	-60.00	108.51	449.53	1.58	358.50	590.87
2.0 to 2.5	145.74	-41.28	83.19	532.72	0.96	342.50	766.12
2.5 to 3.0	114.38	-31.36	65.03	597.75	0.59	326.50	933.37
3.0 to 3.5	88.98	-25.44	50.83	648.58	0.36	310.50	1092.62
3.5 to 4.0	67.22	-21.76	39.05	687.63	0.20	294.50	1243.87
4.0 to 4.5	48.02	-19.20	28.81	716.44	0.10	278.50	1387.12
4.5 to 5.0	30.42	-17.60	19.61	736.05	0.04	262.50	1522.37
5.0 to 5.5	13.78	-16.64	11.05	747.10	0.01	246.50	1649.62
5.5 to 5.9	0.85	-12.93	2.92	750.02	0.00	-----	-----
5.5 to 6.0						230.50	1768.87
6.0 to 7.0						198.50	1983.37
7.0 to 8.0						166.50	2165.87
8.0 to 9.0						134.50	2316.37
9.0 to 10.0						102.50	2434.87
10.0 to 11.0						70.50	2521.37
11.0 to 12.0						38.50	2575.87
12.0 to 13.0						6.50	2598.37
13.0 to 13.2						0.10	2599.03

NOTE: The length of the intervals is varied to suit the portion of the flight being studied. All distances are in feet, velocities in feet per second, and drag is in ounces.

most important on lightweight, fast-moving models. While the performance of heavier rockets can be improved by cleaning up the design to eliminate unnecessary drag, lightweight models will show considerably more improvement when they are reworked to reduce drag. Misaligned fins, extra-large launching lugs, unsanded balsa, unnecessary "doo-dads" on the rocket, etc. all contribute to increased drag. The effects of this extra drag will be especially important when more powerful engines are used in the model. By comparing computed altitudes with tracked altitudes the modeler can determine whether his rocket is aerodynamically clean or if it needs improvement.

23. Further studies in the mathematics of rocket flight can be quite valuable to the rocketeer who is working on a science fair project. By computing performance data for various sizes of engines, different rocket weights, and different amounts of drag he can gain an understanding of the principles involved that will help him greatly in carrying out more advanced research.



Crossword Puzzle Solution . . . for the puzzle appearing on page 3 of MRN Vol. 4, No.1 Feb., 1964.

1	P	2	M	3	G	4	D	5	C	6	L	7	I	8	P	9	F	10	I	11	T	12	S	13	H	14	I	15	P		
16	R	17	O	18	D	19	P	20	R	21	O	22	P	23	R	24	O	25	P	26	U	27	L	28	S	29	I	30	O	31	N
32	O	33	R	34	A	35	N	36	G	37	E	38	D	39	G	40	41	42	43	44	45	46	47	48	49	50	51	52	53	54	
55	P	56	A	57	Y	58	L	59	O	60	A	61	D	62	S	63	64	65	66	67	68	69	70	71	72	73	74	75	76	77	
78	E	79	L	80	L	81	P	82	I	83	A	84	N	85	T	86	87	88	89	90	91	92	93	94	95	96	97	98	99	100	
101	L	102	Y	103	L	104	B	105	G	106	107	108	109	110	111	112	113	114	115	116	117	118	119	120	121	122	123	124	125	126	
127	A	128	C	129	W	130	O	131	132	133	134	135	136	137	138	139	140	141	142	143	144	145	146	147	148	149	150	151	152	153	
154	N	155	A	156	D	157	I	158	R	159	X	160	161	162	163	164	165	166	167	168	169	170	171	172	173	174	175	176	177	178	
179	T	180	O	181	R	182	B	183	S	184	185	186	187	188	189	190	191	192	193	194	195	196	197	198	199	200	201	202	203	204	
205	S	206	C	207	E	208	1	209	210	211	212	213	214	215	216	217	218	219	220	221	222	223	224	225	226	227	228	229	230	231	
232	E	233	S	234	235	236	237	238	239	240	241	242	243	244	245	246	247	248	249	250	251	252	253	254	255	256	257	258	259	260	

the "Flying Jenny"

ROCKET PLAN No. 21

Designed by **John Belkewitch**

A ROCKET BOOSTED BI-PLANE GLIDER!

© Estes Industries, Inc., Penrose, Colo. 1964

Before starting construction, trace all the pattern pieces onto another sheet of paper. Do not cut the patterns from this page as important instructions for building and trimming this bird are on the other side.

Listed below are the materials you will need to complete this unusual boost-glider. Careful construction and attention to trimming will reward you with many beautiful flights.

Full Size Patterns!

PARTS LIST

1	Nose Cone	#BNC-20A
1	Body Tube	#BT-20J
3	Sheets Fin Stock	#BFS-50
1	Launching Lug	#LL-1A
1	Nose Cone Weight	#NCW-1

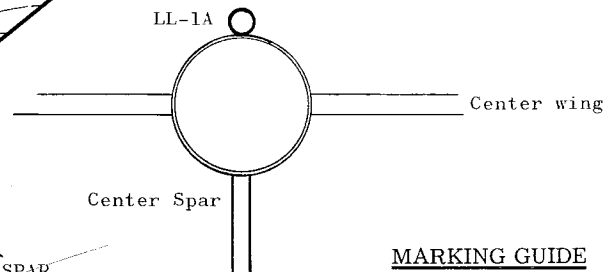
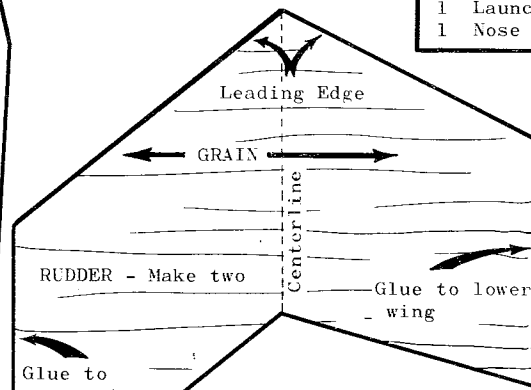
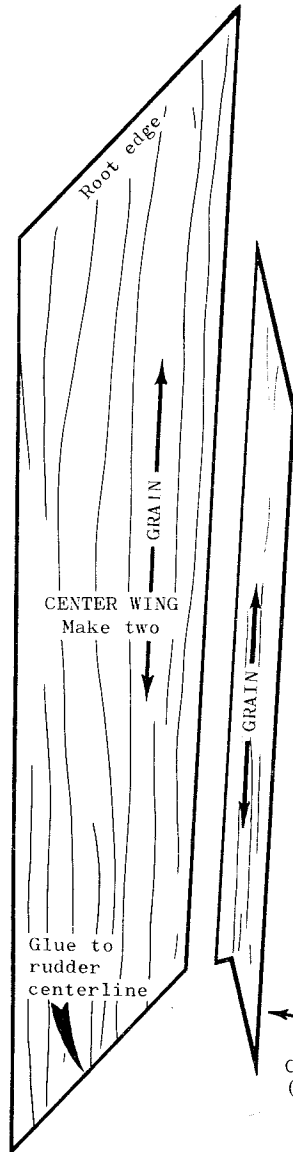
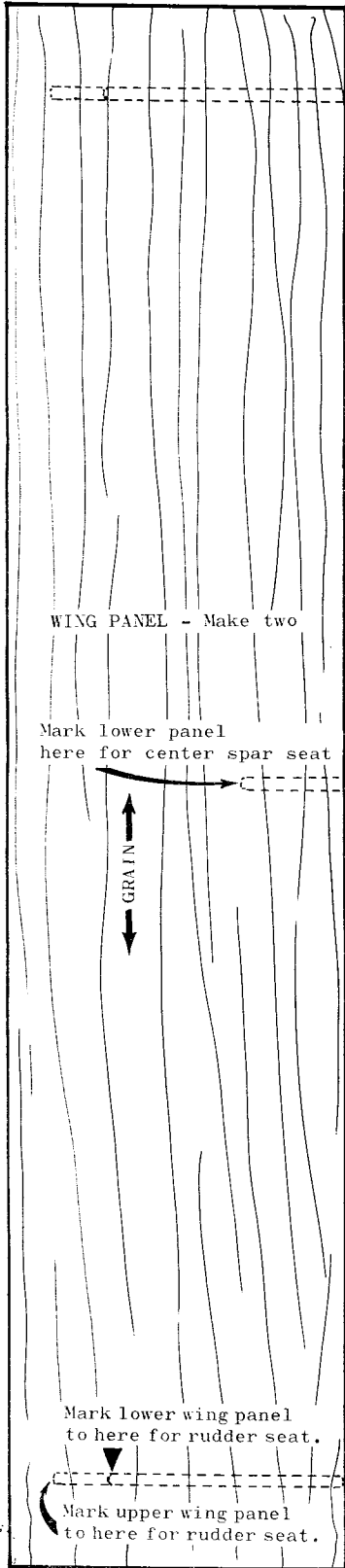

MARKING GUIDE

Place rear of engine tube on guide with launching lug positioned as shown and mark tube for center wing and center spar locations.

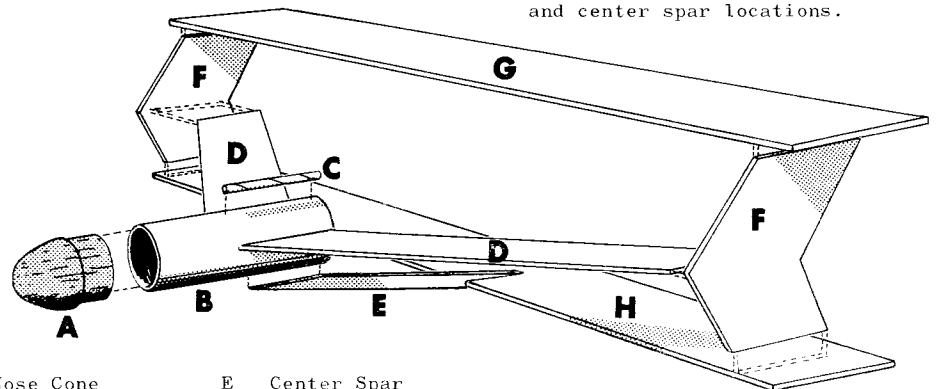

- A Balsa Nose Cone
- B Engine Tube
- C Launching Lug
- D Center Wing Panels
- E Center Spar
- F Left and Right Rudders
- G Upper Wing Panel
- H Lower Wing Panel

Continued on Next Page...

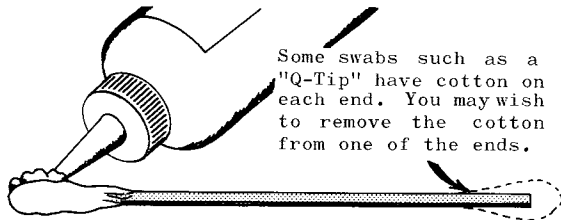

Some swabs such as a "Q-Tip" have cotton on each end. You may wish to remove the cotton from one of the ends.

ROGER BERRY, CARLISLE, MASS. Shows us how to save time and temper when applying glue to the inside of body tubes and other hard-to-reach places. Simply apply a liberal amount of glue to the cotton swab, insert it into the work to the desired depth and roll on the glue.

SECOND PLACE WINNER IN IDEA BOX CONTEST

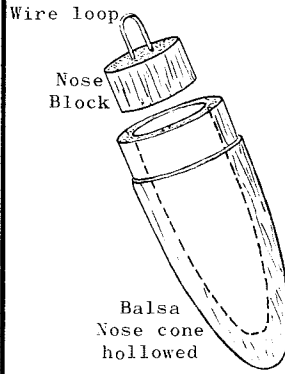

Split with the grain

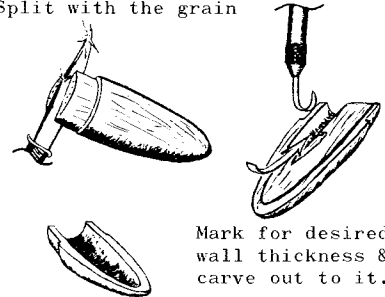

Mark for desired wall thickness & carve out to it.

1/2 of BNC; carving done

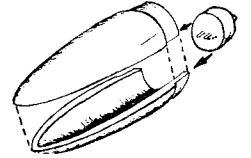

Balsa nose cones can be made even lighter for that special bird by hollowing them as shown.

Splitting the nose cone lengthwise is best for it gives a perfectly matched seam for gluing after the cone has been hollowed. If you do not have a wood carving set, a satisfactory blade can be made from a KNB-1A blade. Sharpen on one side and then bend into a gentle curve as shown. This and a KNB-1C-blade should be all you need.

Glue completed BNC halves together and trim an NB to proper size to act as an end plug and place for a screw eye or wire loop.

THE IDEA BOX

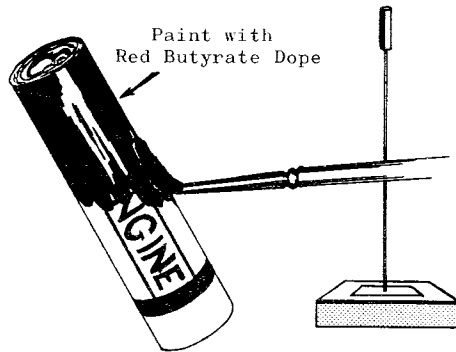

Paint with Red Butyrate Dope

Our thanks to D. WAYNE BRADBURY of GENEVA OHIO, for this range safety tip. To eliminate that chance of bending over and poking an eye out on a launch rod, Wayne suggests packing a wad of glue-soaked tissue into the ejection end of an expended engine and then painting the casing red. After a shot just replace the protector on the rod tip as you go to recover the rocket.

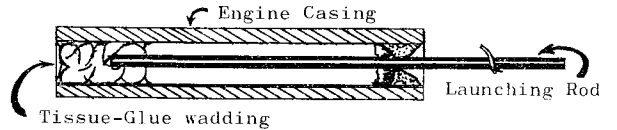

ALAN HALLMAN, OF COLLEGEVILLE, PA. tells of a simple maintenance job to make sure of a long life for his launching equipment.

Just polish your launch rod with steel wool every time it begins to show rust or has been used in an afternoon of firing. This not only saves the rod but makes it work smoother as well. Thanks for your hint Alan...and here's another along that same line. Just be sure to give the rod a light-wax coating after the polish.

8TH PLACE WINNER

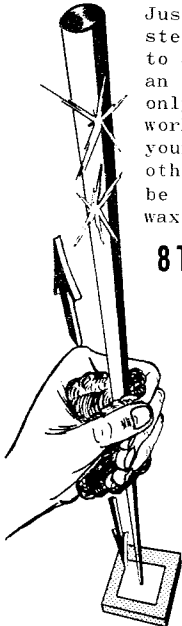

ROBERT BURNEY, of SAN ANTONIO, TEXAS sends his idea of a simple-to-make tool, which Robert says can be anything from a glue dispenser or parachute packer, to a holder for painting your bird. For painting, we'd recommend using a longer dowel than is shown here, but to make the tool, just bore out the nozzle to the size of the dowel, put glue on the dowel and insert into the nozzle approximately 1/2". For a long lasting joint fill the exposed nozzle area with a tissue-glue fillet extending to the edges of the casing.

5TH SPOT!

HANDLE

1/8" to 1/4" doweling...

...2 to 6 inches long.

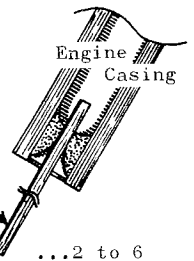

HERE IS HOW ROBERT MAKES A GLUE DISPENSER. . .

Cut felt just larger than end of casing, then tack to the end of the casing.

To use, put liberal amount of glue on felt and swab around area to be coated.

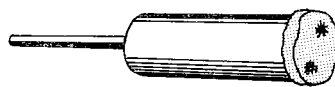

Use in BT-40 BT-50 BT-60

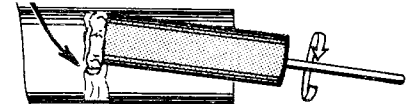

Make several of these handy holders. You'll find many other uses for them beyond what is shown here. Save your expended Series I or II engine casings from the next flight-date. Glue each one to the center of a 4"x 4" piece of cardboard. These holders will make an excellent stand for those birds not able to stand alone due to fin design.

4"x 4" Cardboard Engine casing Glue

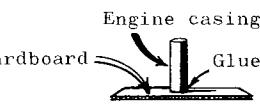

Use as Bird Perch or Parts holder

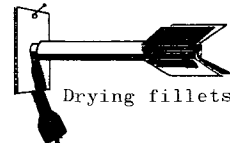

Drying fillets

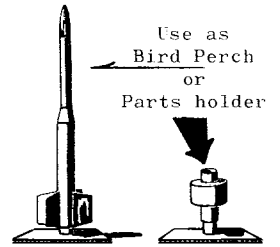

More Idea Box Contest Winners in the Next Big Issue of MODEL ROCKET NEWS

You may wish to hang one on a wall hook to hold the bird horizontally while the glue fillets dry. Perhaps a sub-assembly must be held a certain way 'till dry...use a holder for that job too.

the "Flying Jenny" continued...

Glue a BNC-20A nose cone to one end of the BT-20J engine tube. Install a launching lug so the rear of the lug is flush with the rear of the BT-20J. Place this assembly on the marking guide shown on the foregoing

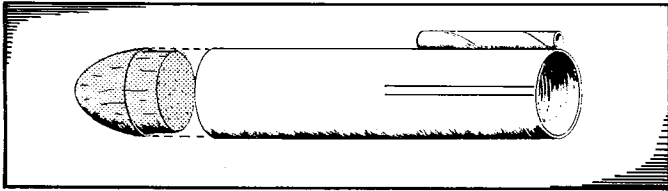

page and mark the positions of the center wing roots and the center spar. Install the center wings and let them dry. Support them horizontally while drying.

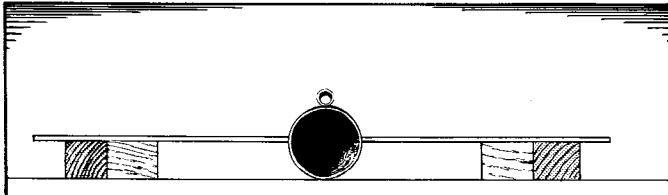

Attach the center spar to the engine tube in line with the marks. This spar prevents wing vibration; and is necessary to keep the wings from coming off in flight.

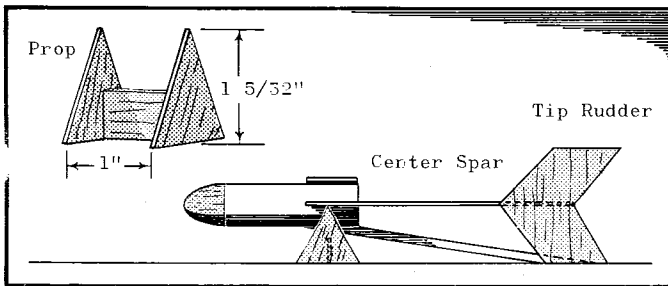

Cut two triangle shaped pieces of wood from scrap measuring $1 \frac{5}{32}$ " from base to top. Glue these pieces to a 1" piece of scrap to form a prop to align and support the engine tube assembly at the center wing roots while the rudders are being glued into position on the center wing tips. The bottom edges of the rudders must rest squarely on the table top as is shown. Let this assembly dry thoroughly before moving.

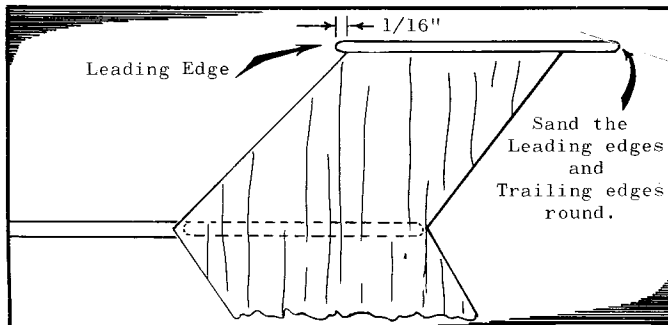

When rudders have set, glue the top wing into place, locating it in the position marked on the pattern. When this has set, turn the model over and glue the bottom wing into place, locating it in the same way. Allow the entire assembly to dry completely. White glue becomes clear when completely cured.

Trimming for Flight

After all glue joints have turned clear, test glide the model by grasping it at the center spar and tossing

it into the wind with nose level. If the model stalls, add a sliver of lead nose cone weight (NCW-1) to the nose.

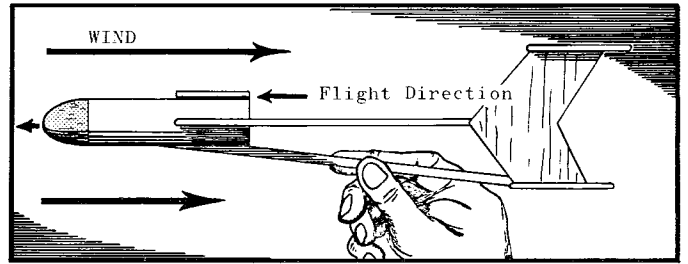

If the model dives, observe whether it also turns to the right or left as it dives. If it does, you may compensate for the turn at the same time you correct the dive.

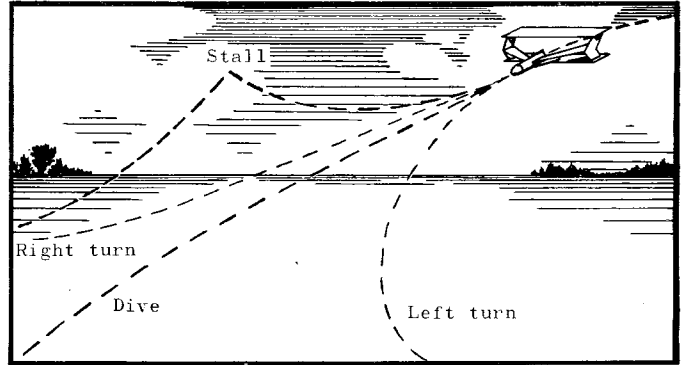

For example: Your model drops quickly and to the right. Cut a sliver of lead from the NCW-1 (only experience can tell you how much) and attach it near the trailing edge of the lower wing perhaps an inch left of the center.

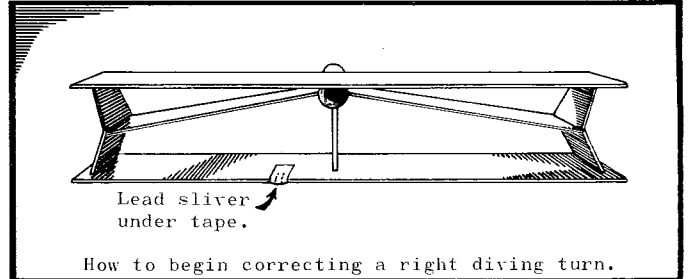

Continue to glide and adjust until a smooth straight ahead glide is obtained. Now you are ready for power.

To Power your "Jenny"...

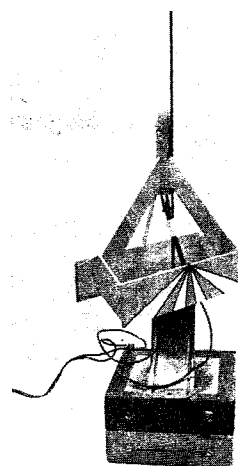

Your "Flying Jenny" will fly with any Series I or Series III engine. Any single stage engine up to and including the A.8-3 is recommended for sport and exhibition flying. However if you have a large flying field and like the hiking then go ahead... put a B.8-4 engine in and watch "Jenny" head into the wild blue yonder... perhaps, for keeps!

CAUTION! Tape your lead wires to the launching rod leaving just enough free to attach micro-clips to the igniter. This will keep the wires from tangling in the wings when launching.

Estes Industries Rocket Plan No. 22

Tiger Shark

Two-Stage Rocket with Gliding Booster!

Published as a service to its customers by Estes Industries, Inc., Penrose, Colo. ©Estes Industries 1964

Gather the modeling tools you will need--scissors, a knife, a bottle of white glue, sheets of medium and fine sandpaper and a ruler.

Begin Construction

To preserve the plans and the instructions on the other side, carefully trace the fin patterns onto another sheet of paper. If you have carbon paper you can trace the patterns directly onto the balsa fin stock. By placing the patterns as shown in Fig. 1 you will get all the booster fins from one piece of balsa. The upper stage fins will come from the second piece, leaving some to spare.

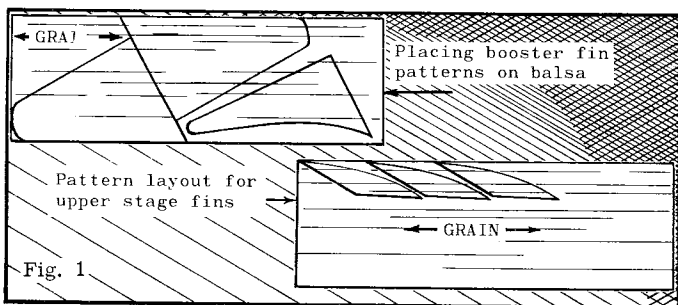

Give all the fins a first sanding, rounding all but the root edges as shown in Fig. 2. Sand all flat surfaces with the grain to give a smooth surface.

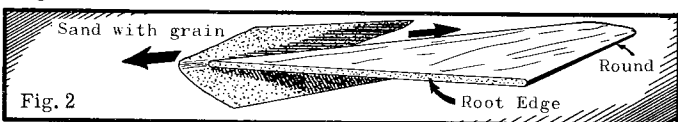

- THIS MUST BE DONE CORRECTLY -

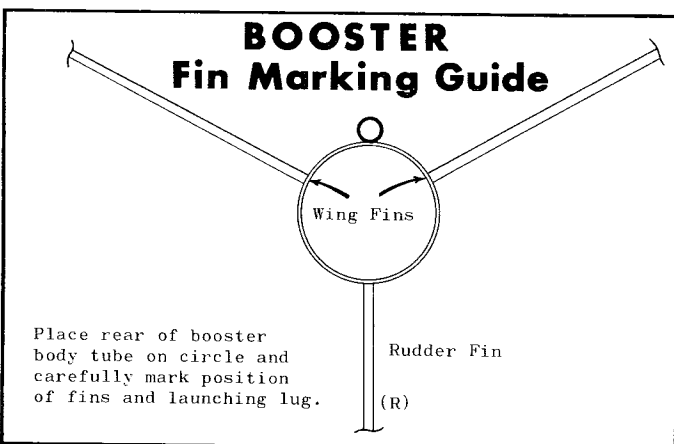

Use the booster fin guide (shown above) to mark the booster body tube. Three fins are used, and they must be placed in the correct relationship to the others in order to make the booster glide. The small fin is the rudder. Place a small "R" by your mark on the body tube for this fin so there will be no confusion

PARTS LIST

- 1 Body Tube #BT-20D
- 1 Body Tube #BT-20G
- 1 Nose Cone #BNC-20N
- 2 Sheets Fin Stock #BFS-20
- 1 Screw Eye #SE-1
- 1 Tape Disc #TD-1
- 2 Engine Blocks #EB-20A
- 1 Shock Cord #SC-1
- 1 Launching Lug #LL-1C
- 1 Streamer #SM-1

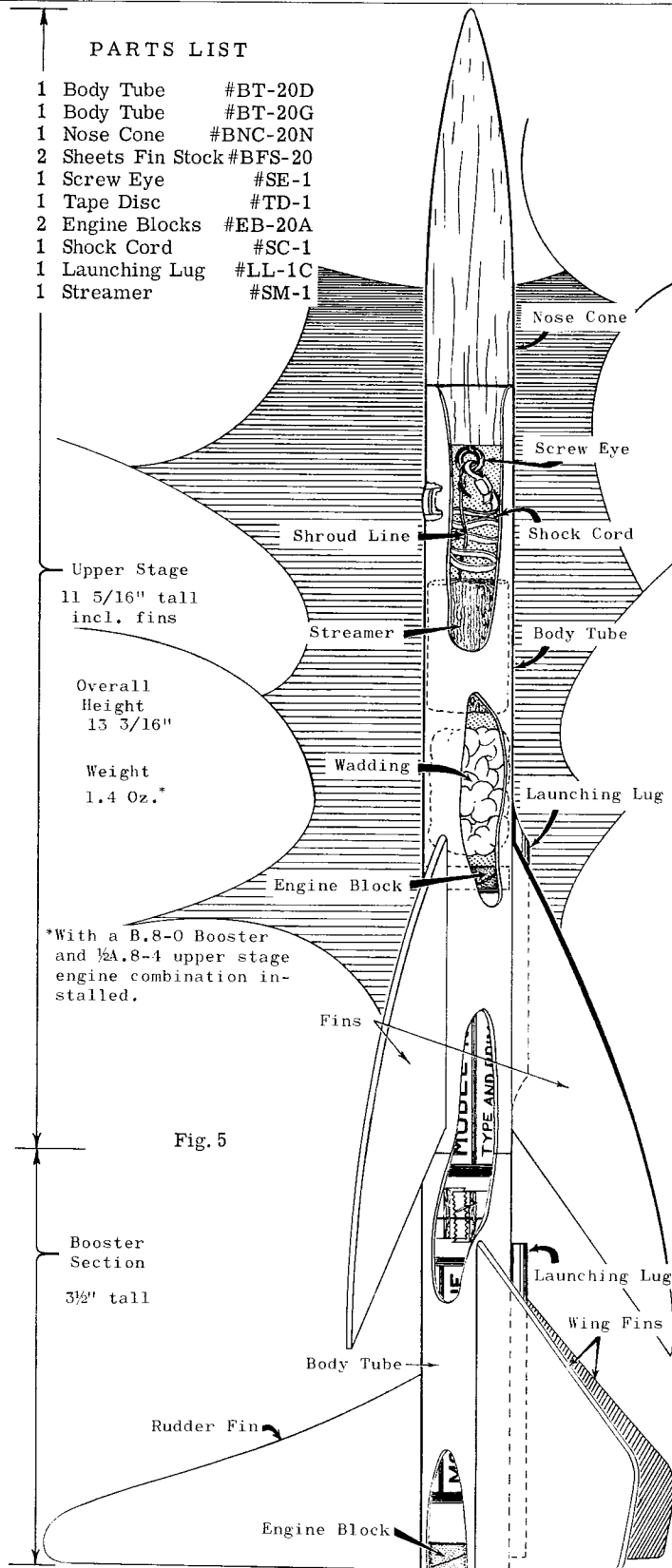

*With a B.8-0 Booster and 1/2 A.8-4 upper stage engine combination installed.

when gluing on the fins. Don't glue the engine block in the 3.5" long BT-20G booster body yet. Since the weight of balsa varies from one sheet to the next you should fine-trim your booster by test gliding with an expended engine casing in place. By moving the engine casing forward or back a fraction of an inch, a clean rudder-up glide of 15 or more feet should be obtained from a hand toss. When you have located the best position mark the inside of the tube at the nozzle end of the engine casing and glue the engine block into the tube with the forward edge of the block against the mark. Fig. 3 shows the center of gravity for the booster without the engine casing, but with all other parts of the stage in place.

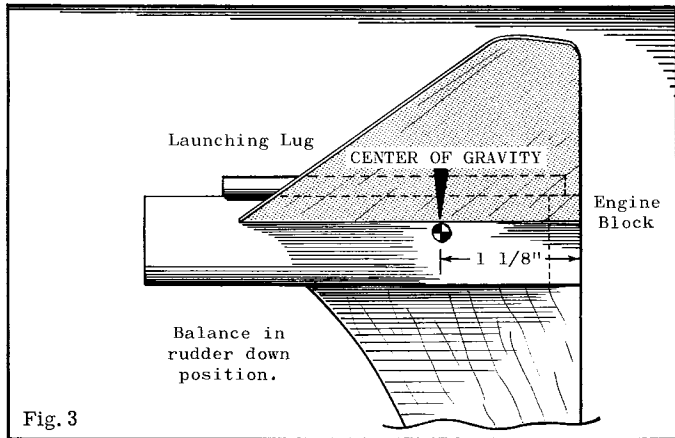

Fig. 3

BUILDING THE UPPER STAGE

Use the standard procedure for building the upper stage. A streamer recovery is used for obvious reasons. Mark and line the positions of the fins using the marking guide in Fig. 4. Next

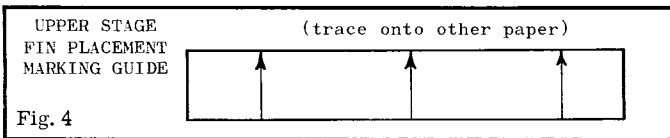

Fig. 4

tape a couple of engine casings together and insert one end into the booster section. Smear glue with a brush or finger about 2" up into the back end of the 6.5" body tube you have just marked for the fins. Place the second engine block into the end of the body tube and push it into place with engines and booster. This assures proper placement of the engine block in the upper stage and perfect mating of the two body tube sections.

Install a launching lug in the position shown in Fig. 5. Install the shock cord and the screw eye in the usual way, then attach the streamer.

FINISHING INFO

Touch up any rough balsa surfaces with extra fine sandpaper. Apply sanding sealer evenly to the balsa and let it dry thoroughly. Sand with extra fine sandpaper, apply more sanding sealer, let dry and sand again. Repeat this procedure as necessary until the balsa is mirror-smooth. Apply at least one even base coat of white dope or enamel to provide a clean background for following colors. Give the rocket at least one final coat of red, a fluorescent color or any other high visibility color to aid in tracking. CAUTION: Enamel paint may be applied over a coat of thoroughly dry butyrate dope, but butyrate dope should never be applied over enamel as the dope will make the enamel under it bubble.

PRELAUNCH STEPS

Tape an upper and lower stage engine together as described in TR-2, using cellophane tape. The lower stage engine should make a snug fit in the booster section. Usually one layer of tape

is enough to make an upper stage engine fit tightly in place. As you press the two units together, line up the launching lugs. Install wadding and pack the streamer and shock cord into place and top off with the nose cone. Install the igniter.

Assign at least one observer to watch each stage. On first flights use an A. 8-0 booster engine and a 1/4A. 8-4 upper stage engine. The booster should glide 16 seconds or more. The test models averaged 30 seconds with B. 8-0 engines.

